

Roller Support Assembly

Maia Judd

GC 120 003

Spring Semester

4/22/2020

NOTE: EACH GRID SQUARE
REPRESENTS 10 mm

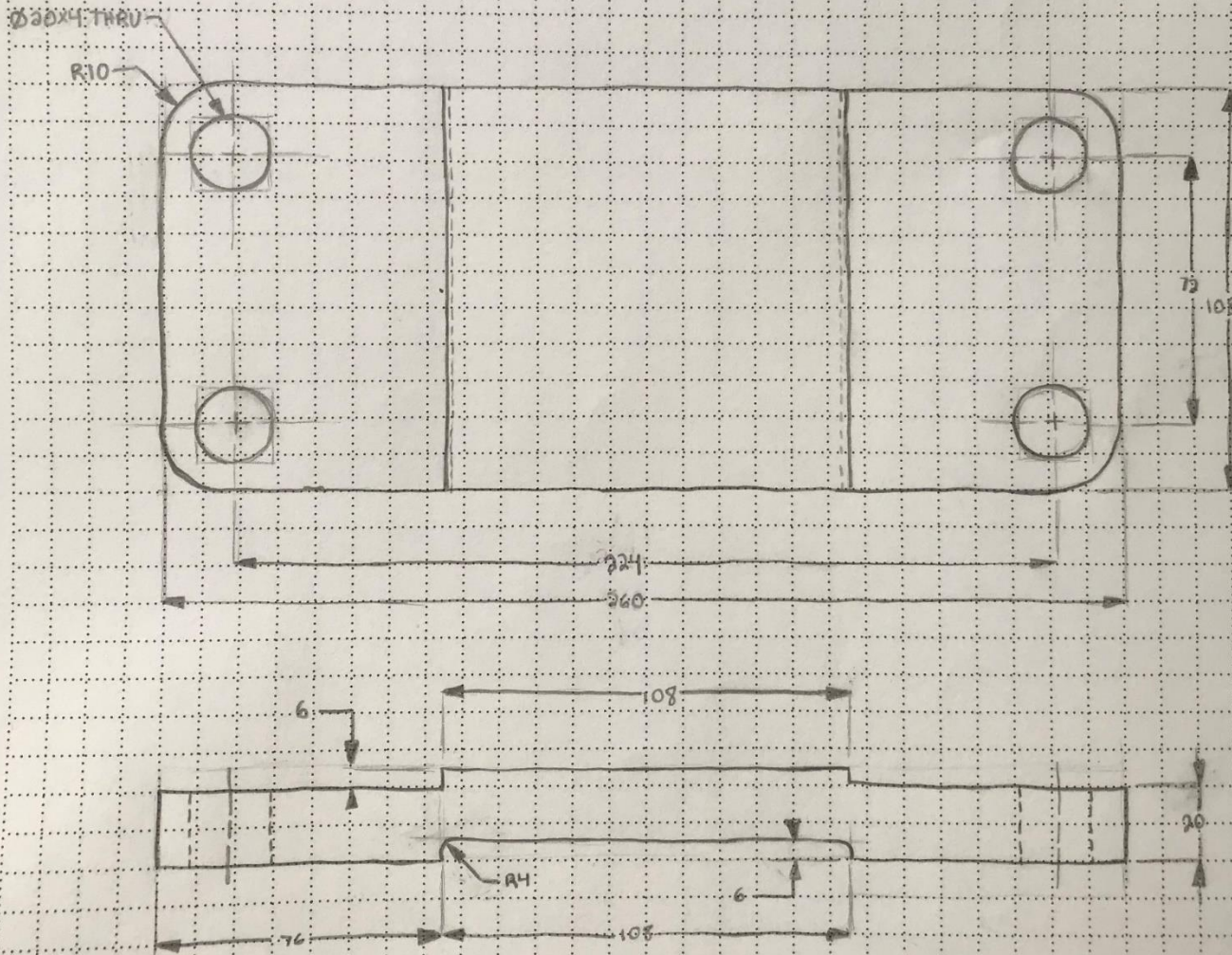

DRAWN BY: MATA JUDD

TITLE: BASE PLATE

COURSE: GC 120

SECTION: 003

SCALE: 1:2

DATE: 4/21/2020

GRID
SQR.

REV 2008

THE INFORMATION CONTAINED IN THIS DRAWING IS THE SOLE PROPERTY OF NC STATE UNIVERSITY. ANY REPRODUCTION IN PART OR WHOLE WITHOUT THE WRITTEN PERMISSION OF NC STATE UNIVERSITY IS PROHIBITED.
 Unit: Base Plate

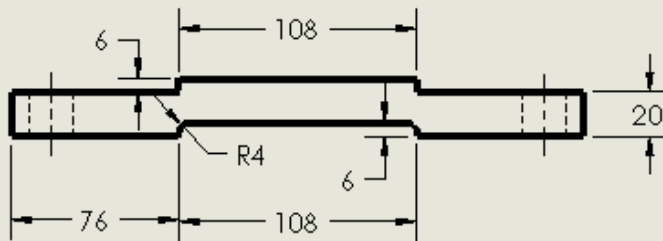
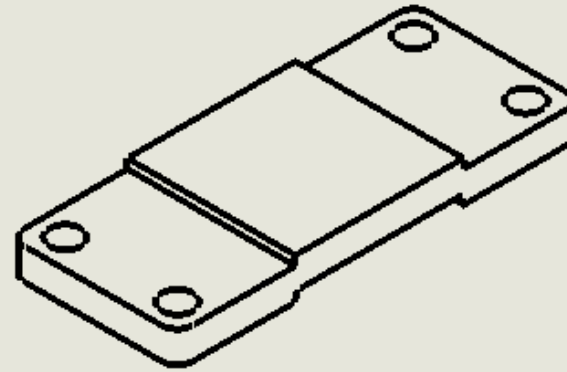
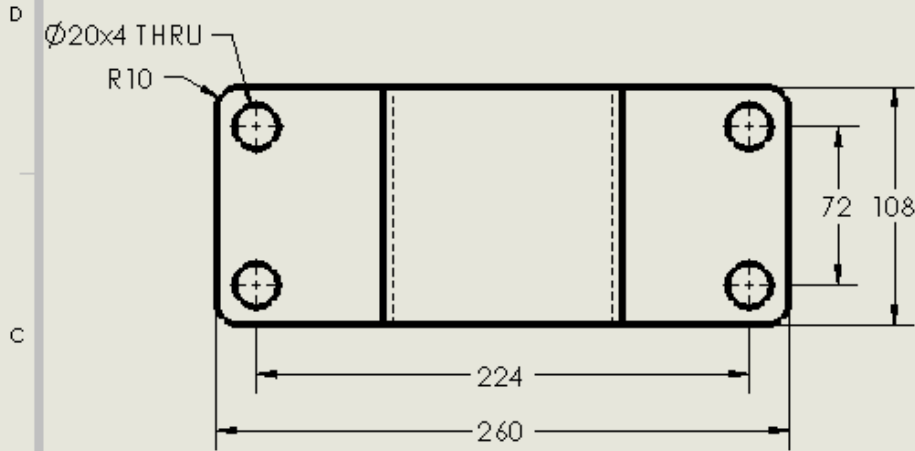

NORTH CAROLINA STATE UNIVERSITY
 P.O. BOX 7801
 Raleigh, North Carolina

UNLESS OTHERWISE SPECIFIED
 DIMENSIONS ARE IN MILLIMETERS
 TOLERANCES ARE:
 FINISHES DECIMALS ANGLES
 - .00 - .02 - 1
 XXX-XXX

DRAWN MAIA JUDD
 MATERIAL 1010 STEEL

DATE 4/21/2020
 SCALE 1:3

TITLE BASE PLATE
 SET A PROJ. NO. TERM PROJECT

1

THE INFORMATION CONTAINED IN THE DRAWING IS THE SOLE PROPERTY OF NC STATE UNIVERSITY. ANY REPRODUCTION IN PART OR WHOLE WITHOUT THE WRITTEN PERMISSION OF NC STATE UNIVERSITY IS PROHIBITED.
 H11: Bell Roller

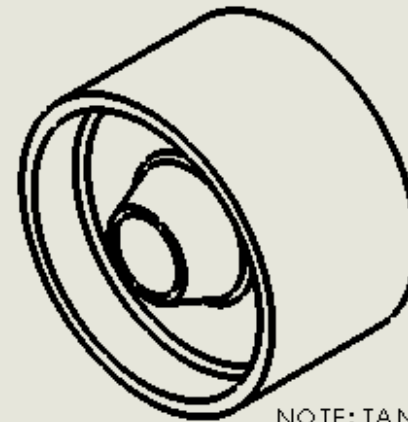
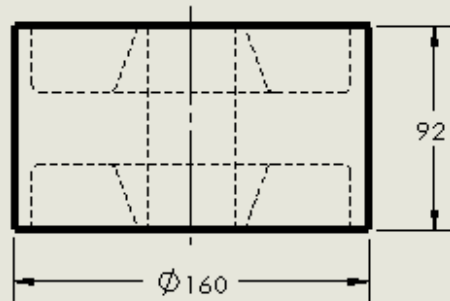

NOTE: TANGENT EDGES ARE SHOWN SO FILLETS R4 CAN BE SEEN

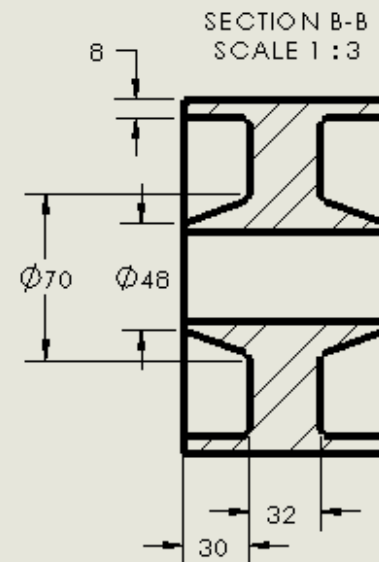
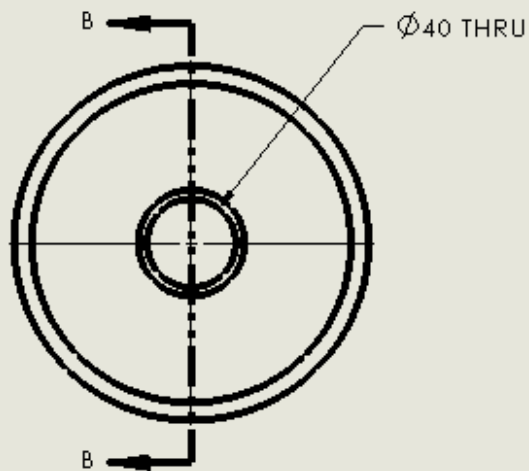

NORTH CAROLINA STATE UNIVERSITY
 P.O. BOX 7801
 Raleigh, North Carolina

UNLESS OTHERWISE SPECIFIED
 DIMENSIONS ARE IN MILLIMETERS
 TOLERANCES ARE:
 FRACTIONS DECIMALS ANGLES
 - XX-XX -1
 XXX-XXX

DRAWN
 MAIA JUDD
 MATERIAL
 1010 STEEL

DATE
 4/21/2020
 SCALE
 1:3

TITLE
 BELL ROLLER
 SET NO.
 A
 TERM PROJECT

1

THE INFORMATION CONTAINED IN THIS DRAWING IS THE SOLE PROPERTY OF NC STATE UNIVERSITY. ANY REPRODUCTION IN PART OR WHOLE WITHOUT THE WRITTEN PERMISSION OF NC STATE UNIVERSITY IS PROHIBITED.
 111: Bracket

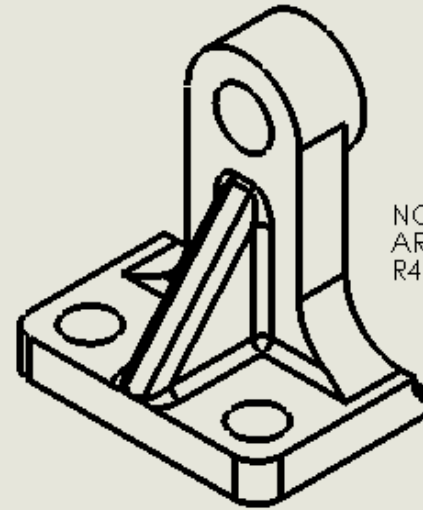
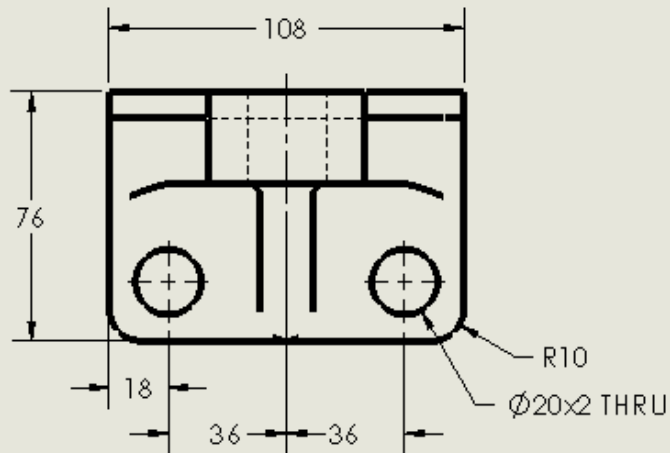

NOTE: TANGENT EDGES ARE SHOWN SO FILLETS R4 CAN BE SEEN

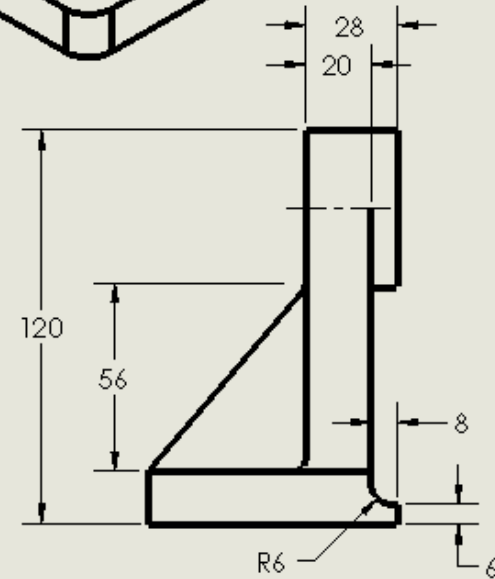
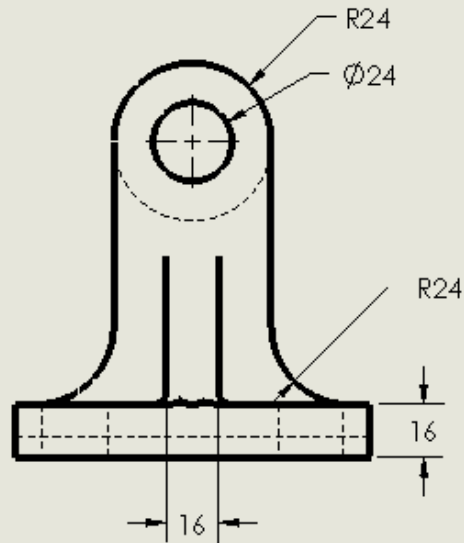

NORTH CAROLINA STATE UNIVERSITY

P.O. BOX 7801
 Raleigh, North Carolina

UNLESS OTHERWISE SPECIFIED
 DIMENSIONS ARE IN MILLIMETERS
 TOLERANCES ARE:
 FINISHES: DIMMALS AND 1/16
 - .00 - .00 - .1
 XXX-XXX

DATE

MAIA JUDD

DATE

4/21/2020

NAME

BRACKET

MATERIAL

CAST IRON

SCALE

1:2

SHEET

A

PROJ. NO.

TERM PROJECT

1

THE INFORMATION CONTAINED IN THE DRAWING IS THE SOLE PROPERTY OF
 NC STATE UNIVERSITY. ANY REPRODUCTION IN PART OR WHOLE WITHOUT
 THE WRITTEN PERMISSION OF NC STATE UNIVERSITY IS PROHIBITED.
 REF: BUSHING

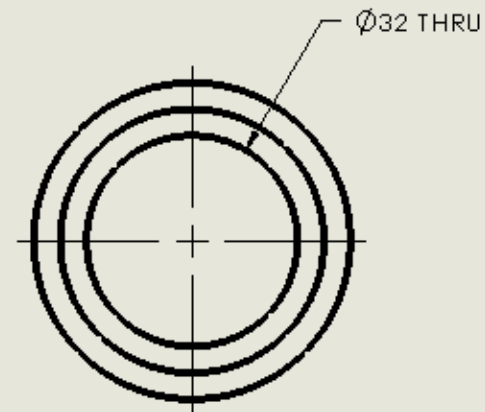
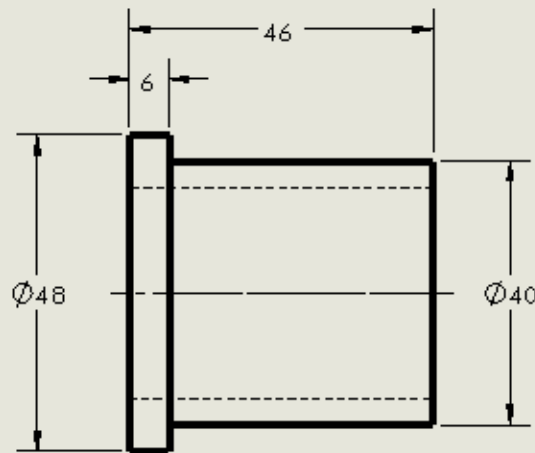
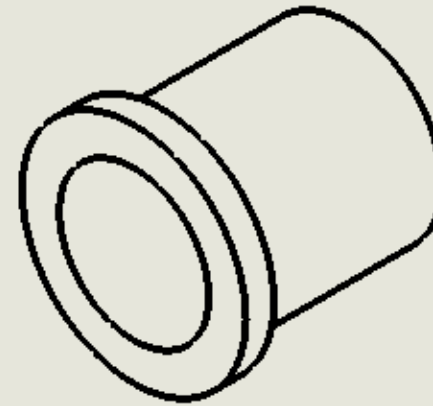

NORTH CAROLINA STATE UNIVERSITY

P.O. BOX 7801
 Raleigh, North Carolina

UNLESS OTHERWISE SPECIFIED
 DIMENSIONS ARE IN MILLIMETERS
 TOLERANCES ARE:
 FINISHES: DIMASD ANGLES
 - XX-XX -1
 XXX-XXX

DRAWN
 MAIA JUDD

MATERIAL
 BRASS

DATE
 4/21/2020

SCALE
 1:1

TITLE
 BUSHING

SHEET NO.
 A TERM PROJECT

OF
 1

THE INFORMATION CONTAINED IN THIS DRAWING IS THE SOLE PROPERTY OF NC STATE UNIVERSITY. ANY REPRODUCTION IN PART OR WHOLE WITHOUT THE WRITTEN PERMISSION OF NC STATE UNIVERSITY IS PROHIBITED.
 HJT:Snaf

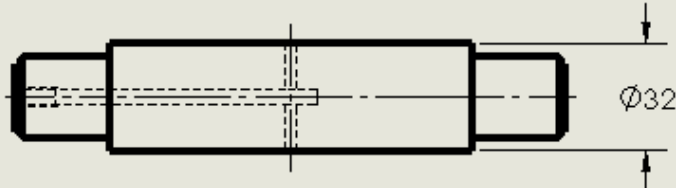
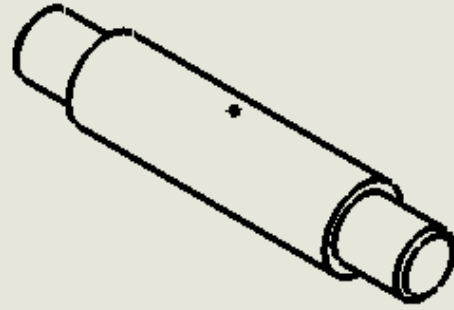
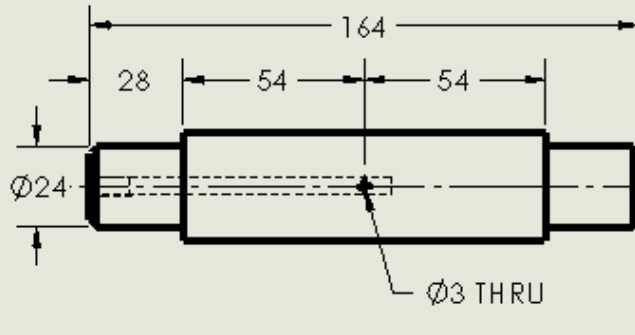

NORTH CAROLINA STATE UNIVERSITY
 P.O. BOX 7801
 Raleigh, North Carolina

UNLESS OTHERWISE SPECIFIED
 DIMENSIONS ARE IN MILLIMETERS
 TOLERANCES ARE:
 FRACTIONS DECIMALS ANGLES
 XX-XX -1
 XXX-XXX

DRAWN
 MAIA JUDD
 MATERIAL
 1010 STEEL

DATE
 4/21/2020
 SCALE
 1:2

TITLE
 SHAFT
 SHEET NO.
 A
 PROJ. NO.
 TERM PROJECT
 1

1 2 3 4 5 6 7 8

THE INFORMATION CONTAINED IN THIS DRAWING IS THE SOLE PROPERTY OF NORTH CAROLINA STATE UNIVERSITY. ANY REPRODUCTION IN PART OR WHOLE WITHOUT THE WRITTEN PERMISSION OF NORTH CAROLINA STATE UNIVERSITY IS PROHIBITED.
 File: Judd_m_termProject_Assembly

ITEM NO.	PART NUMBER	MATERIAL	QTY.
1	Base Plate	AISI 1010 Steel, hot rolled bar	1
2	Bracket	Gray Cast Iron	2
3	Shaft	AISI 1010 Steel, hot rolled bar	1
4	Bell Roller	AISI 1010 Steel, hot rolled bar	1
5	Bushing	Brass	2
6	Hex Head Screw	Steel	4
7	Grease Fitting	AISI 1010 Steel, hot rolled bar	1

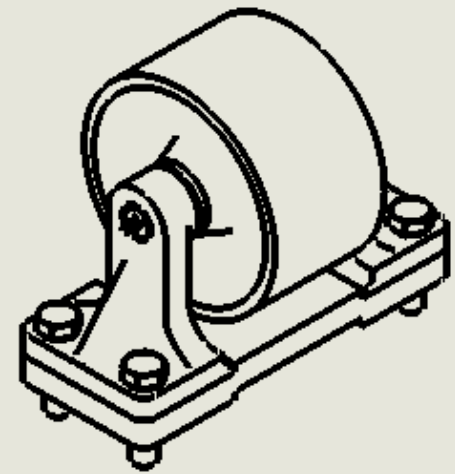
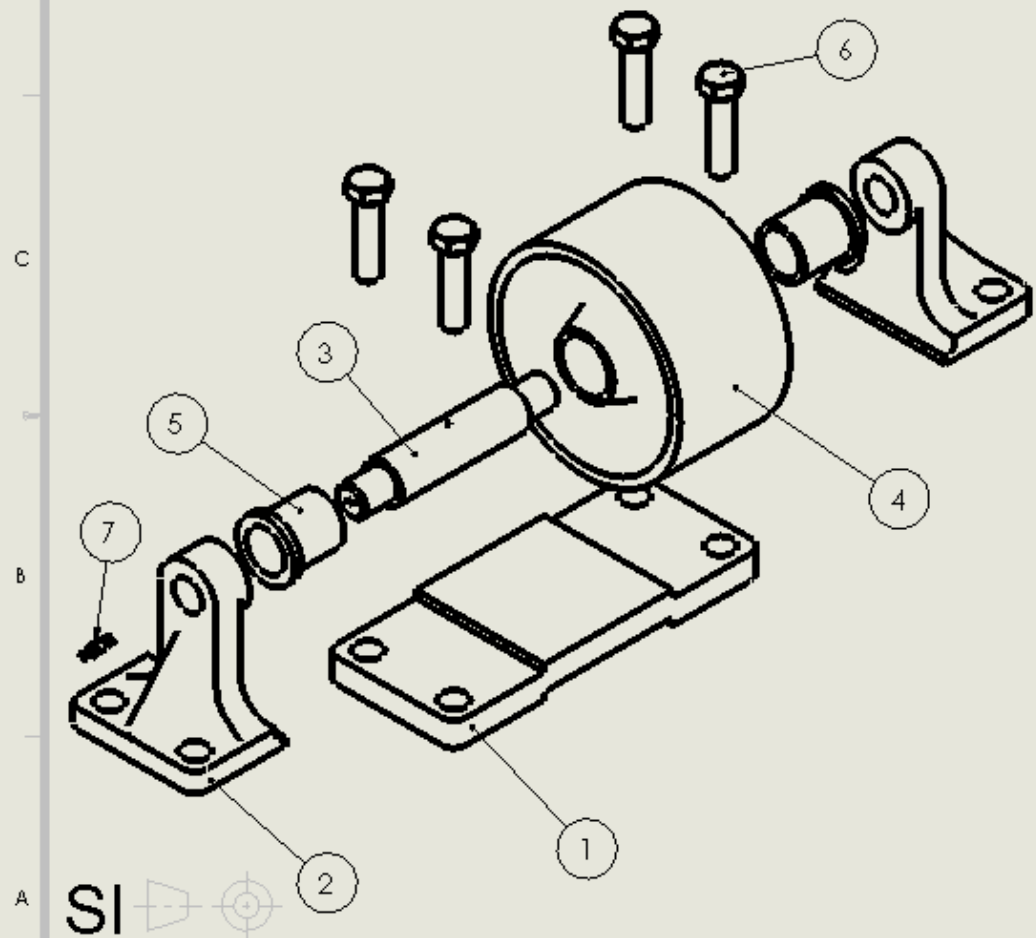

NORTH CAROLINA STATE UNIVERSITY
 P.O. BOX 7801
 Raleigh, North Carolina

UNLESS OTHERWISE SPECIFIED
 DIMENSIONS ARE IN MILLIMETERS
 TOLERANCES ARE:
 FINISHES DECIMALS ANGLES
 - .XX - .XX - 1
 .XXX - .XXX

DESIGN MAIA JUDD
 DATE 4/21/2020
 DRAWN SEE BOM

SCALE 1:4

TITLE ROLLER SUPPORT
 SHEET NO. A
 PROJ. NO. TERM PROJECT

1